

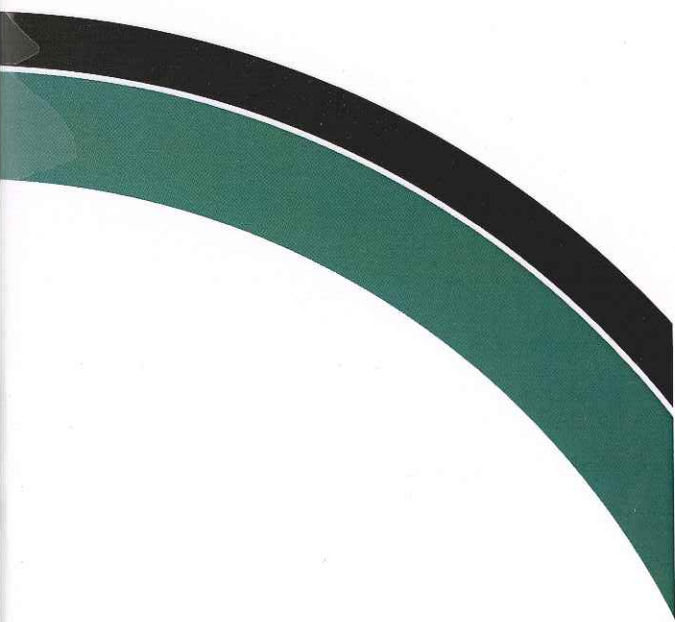

KONTI
HIDROPLAST®

PRODUCTION OF POLYETHYLENE
AND POLYPROPYLENE PIPES



DRAIN PIPE

www.konti-hidroplast.com.mk

CONTENTS

INTRODUCTION	2
KONTI KAN DRAIN PROGRAM	5
HDPE/PP KONTI KAN DRAIN SUBSOIL DRAINAGE PIPE	6
KONTI KAN DRAIN HDPE SMOOTH PIPE	12
KONTI KAN DRAIN PP SUBSOIL DRAINAGE OF TRAFFIC AREAS	16
INSTRUCTIONS FOR TRANSPORTATION AND INSTALLATION	21
STANDARDS	23
CERTIFICATES	24
LABORATORY TESTING	25



KONTI HIDROPLAST®

WELCOME TO OUR WORLD

Konti Hidroplast is part of the world's largest manufacturer and supplier of high performance plastic pipes and offers the best and the most cost effective pipe systems for its customers.

Konti Hidroplast specialises in polyethylene pipe systems for gas and water transportation in the utilities and industrial markets.

MARKET ORIENTED

Konti Hidroplast products find a broad range of applications in the industrial and utilities market on a worldwide scale.

The water and gas distribution enterprises are important sectors for high integrity products where the maintenance of water quality and the safe transport of gaseous fuels are of paramount importance.

Industrial applications include alternative energy installations in landfill gas systems to effluent transportation and mineral slurry.

Products are widely used in pipeline installation, repair and maintenance.

Many of the brands in the Konti Hidroplast portfolio have a long record of innovation in meeting the needs of the water and gas utilities.

Being one of the foremost pioneers in polyethylene pipe systems, Konti Hidroplast is continually improving and updating its offer to meet the ever growing needs of the distribution engineer, ensuring they stay at the forefront of world gas and water distribution/treatment systems.



CUSTOMER FOCUS

The key to our success lies in the commitment to provide the highest quality service and support. We are a team of highly motivated and experienced individuals.

We place the utmost importance on meeting the needs of our customers, constantly evolving our extensive product portfolio to meet the ever changing demands of the water and gas utilities, industrial and foreign markets.

QUALITY

Konti Hidroplast is a result-driven business – its people, products and service. Designed, manufactured and supplied under EN ISO 9001:2000 accredited Quality Management Systems, Konti Hidroplast products comply with relevant national, European and international product standards to ensure complete reliability for our customers.

Besides the ISO certificates for Quality Management Systems and ecology, the gas pipes are also certified by DVGW CERT GmbH.

THE ENVIRONMENT

Committed to sustainable manufacture and systems, Konti Hidroplast operates and maintains an environmental policy fully accredited by ISO 14001.

KONTI KAN DRAIN PROGRAM

KONTI KAN DRAIN program contains two product groups:

1. HDPE/PP KONTI KAN DRAIN SUBSOIL DRAINAGE PIPE

- KONTI KAN DRAIN HDPE /PP Double wall corrugated
- KONTI KAN DRAIN HDPE /PP Smooth pipe

2. KONTI KAN DRAIN PP SUBSOIL DRAINAGE OF TRAFFIC AREAS

A special need requires an adequate solution for drainage of subsoil. Konti Hidroplast is furnished with various equipment which guarantees a wide range of slots and solutions for these products

ADVANTAGE

- Light weight
- High structure
- Large length
- Easy to install
- Flexible
- Chemically inert
- Abrasion resistance
- Cost effective

APPLICATION

- Golf courses
- Landfill
- Parks
- Landscaping
- Agriculture
- Retaining walls
- Highways and roads
- Sludge drying beds

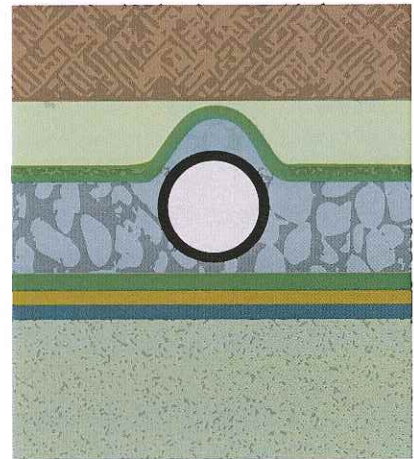

TYPE OF SLOTTING / PERFORATION

- SLOT PATTERN:

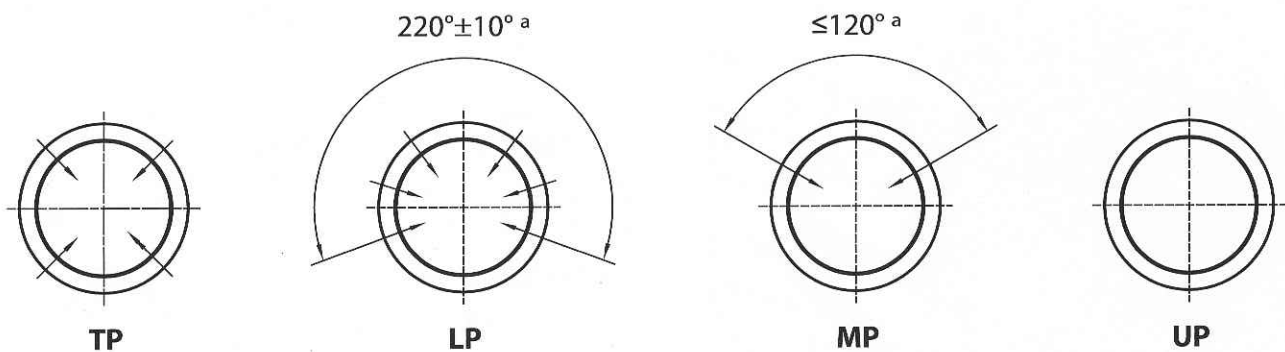

- **(TP)** FULLY SLOTTED over the entire pipe cross section (360°)
- **(LP)** PARTIALLY SLOTTED slotting at approximately 220° of the section
- **(MP)** MULTI PURPOSE slotting at approximately 120 maximum of 160° over cross section.
- **(UP)** UNSLOTTED conveyance pipes (watertight with o-ring, for transporting drainage water)



1. HDPE/PP KONTI KAN DRAIN SUBSOIL DRAINAGE PIPE

**KONTI KAN DRAIN HDPE/PP
DOUBLE WALL CORRUGATED**

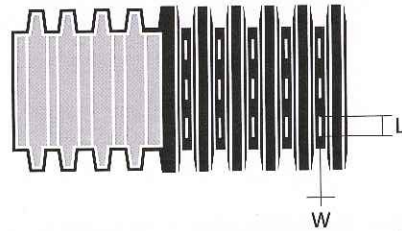

Type R2, pipe with smooth inner surface and profiled external surface.

**KONTI KAN DRAIN HDPE
SMOOTH PIPE**

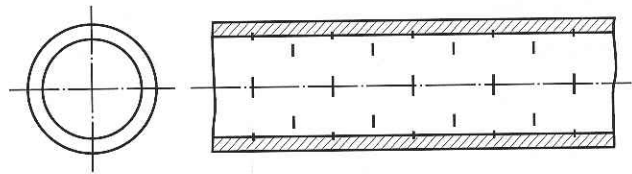

Type R3, circular solid wall pipes with a homogeneous wall structure and a smooth inner and outer surfaces.

**KONTI KAN DRAIN HDPE/PP
DOUBLE WALL CORRUGATED PIPE**

PRODUCT DATA

PRODUCT STANDARD: EN 13476-3

DRAINAGE STANDARD:
BS 4962:1989; DIN4262-1

MATERIAL: HDPE/PP

DIMENSIONS: DN/OD

TABLE 1

Pipe type: R2
 Length: 6 m straight pipe,
 coil length 25 or 50 m
 Number of slots per rib: 2
 Type of perforation: LP

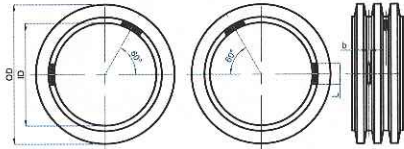

Pipe code OD/2P 220°

220°					
PIPE CODE	OUTER DIAMETER	INNER DIAMETER	COLLECTION SURFACE		NO. OF SLOTS PER METER
-	mm	mm	cm ² /m	% / m	-
OD90/2P	90	81	44	1.7	222
OD110/2P	110	96	39	1.3	174
OD125/2P	125	108	35	1.0	167
OD160/2P	160	138	52	1.2	118
OD200/2P	200	171	39	0.7	89

TABLE 2

Pipe type: R2
 Length: 6 m straight pipe,
 coil length 25 or 50 m
 Number of slots per rib: 3
 Type of perforation: TP

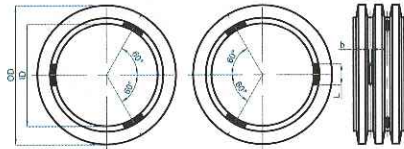

Pipe code OD/3P 360°

360°					
PIPE CODE	OUTER DIAMETER	INNER DIAMETER	COLLECTION SURFACE		NO. OF SLOTS PER METER
-	mm	mm	cm ² /m	% / m	-
OD90/3P	90	81	65	2.6	333
OD110/3P	110	96	58	1.9	261
OD125/3P	125	108	53	1.5	250
OD160/3P	160	138	78	1.8	176
OD200/3P	200	171	59	1.1	133

TABLE 3

Pipe type: R2
 Length: 6 m straight pipe
 Number of slots per rib: 2
 Type of perforation: MP

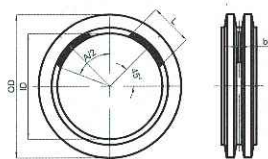

Pipe code ID or OD/2D 130°

130°					
PIPE CODE	OUTER DIAMETER	INNER DIAMETER	COLLECTION SURFACE		NO. OF SLOTS PER METER
-	mm	mm	cm ² /m	% / m	-
OD200/2D	200	171	124	2.3	89
OD250/2D	250	215	142	2.1	74
OD315/2D	315	271	153	1.8	60
OD400/2D	400	348	160	1.4	50

TABLE 4

Pipe type: R2
 Length: 6 m straight pipe
 Number of slots per rib: 3
 Width slot: 4.8 mm
 Type of perforation: MP

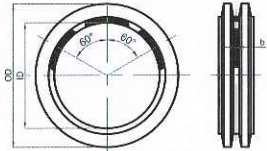

Pipe code ID or OD/3D 160°

160°					
PIPE CODE	OUTER DIAMETER	INNER DIAMETER	COLLECTION SURFACE		NO. OF SLOTS PER METER
-	mm	mm	cm ² /m	% / m	-
OD400/3D	400	348	335	3.0	75
OD500/3D	500	434	402	2.9	58
OD630/3D	630	564	436	2.5	45
OD800/3D	800	694	528	2.4	40
OD1000sn4/3D	1000 SN4	860	439	1.6	29
OD1000sn8/3D	1000 SN8	858	367	1.4	24

TABLE 5

Pipe type: R2
 Length: 6 m straight pipe
 Number of slots per rib: 2.1
 Type of perforation: LP

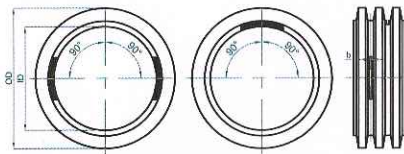

Pipe code ID or OD/2.1D 220°

220°					
PIPE CODE	OUTER DIAMETER	INNER DIAMETER	COLLECTION SURFACE		NO. OF SLOTS PER METER
-	mm	mm	cm ² /m	% / m	-
OD200/2.1D	200	171	149	2.7	67
OD250/2.1D	250	215	142	2.1	56
OD315/2.1D	315	271	129	1.5	45
OD400/2.1D	400	348	120	1.1	38

TABLE 6

Pipe type: R2
 Length: 6 m straight pipe
 Number of slots per rib: 3
 Type of perforation: LP

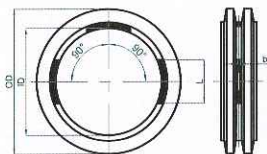

Pipe code ID or OD/3D 200°

220°					
PIPE CODE	OUTER DIAMETER	INNER DIAMETER	COLLECTION SURFACE		NO. OF SLOTS PER METER
-	mm	mm	cm ² /m	% / m	-
OD200/2D	200	171	164	3.0	133
OD250/2D	250	215	206	3.0	111
OD315/2D	315	271	229	2.7	90
OD400/2D	400	348	240	2.2	75

TABLE 7

Pipe type: R2
 Length: 6 m straight pipe
 Number of slots per rib: 4
 Type of perforation: TP

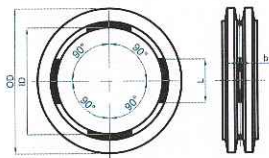

Pipe code ID or OD/4D 360°

360°					
PIPE CODE	OUTER DIAMETER	INNER DIAMETER	COLLECTION SURFACE		NO. OF SLOTS PER METER
-	mm	mm	cm ² /m	% / m	-
OD200/4D	200	171	164	3.0	178
OD250/4D	250	215	204	3.0	148
OD315/4D	315	271	260	3.0	119
OD400/4D	400	348	336	3.0	100

TABLE 8

Pipe type: R2
 Length: 6 m straight pipe
 Number of slots per rib: 6
 Slot width: 4.8 mm
 Type of perforation: TP

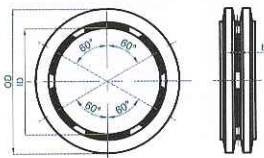

Pipe code ID or OD/6D 360°

360°					
PIPE CODE	OUTER DIAMETER	INNER DIAMETER	COLLECTION SURFACE		NO. OF SLOTS PER METER
-	mm	mm	cm ² /m	% / m	-
OD500/6D	500	434	415	3.0	115
OD630/6D	630	564	524	3.0	91
OD800/6D	800	694	653	3.0	80
OD1000sn4/6D	1000 SN4	860	809	3.0	57
OD1000sn8/6D	1000 SN8	858	734	2.7	48

PRODUCT STANDARD: EN 13476-3
DRAINAGE STANDARD: BS 4962:1989; DIN4262-1
MATERIAL: HDPE/PP
DIMENSIONS: DN /ID

TABLE 9

Pipe type: R2
 Length: 6 m straight pipe
 Number of slots per rib: 2
 Slot width: 3.2 mm
 Type of perforation: MP

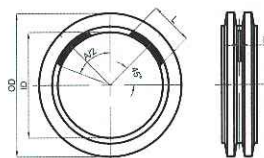

Pipe code ID or OD/2D 130°

130°					
PIPE CODE	OUTER DIAMETER	INNER DIAMETER	COLLECTION SURFACE		NO. OF SLOTS PER METER
-	mm	mm	cm ² /m	% / m	-
ID200/2D	230.6	200	86	1.4	83
ID250/2D	282.6	247	80	1.0	77
ID300/2D	339.7	297	133	1.4	59

TABLE 10

Pipe type: R2
 Length: 6 m straight pipe,
 Number of slots per rib: 3
 Slot width: 4.8 mm
 Type of perforation: MP

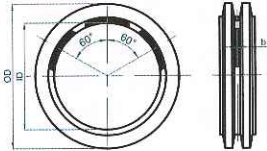

Pipe code ID or OD/3D 160°

160°					
PIPE CODE	OUTER DIAMETER	INNER DIAMETER	COLLECTION SURFACE		NO. OF SLOTS PER METER
			cm ² /m	% / m	
-	mm	mm	cm ² /m	% / m	-
ID400/3D	451.6	395.2	37422	3.0	62
ID500/3D	563	493.4	39715	2.5	53
ID600/3D	678	593	47003	2.5	45
ID800/3D	906	795	42786	1.7	28

TABLE 11

Pipe type: R2
 Length: 6 m straight pipe
 Number of slots per rib: 2.1
 Slot width: 3.2 mm
 Type of perforation: LP

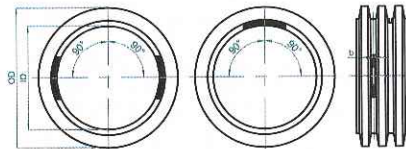

Pipe code ID or OD/2.1D 220°

220°					
PIPE CODE	OUTER DIAMETER	INNER DIAMETER	COLLECTION SURFACE		NO. OF SLOTS PER METER
			cm ² /m	% / m	
-	mm	mm	cm ² /m	% / m	-
ID200/2.1D	230.6	200	139	2.2	62
ID250/2.1D	282.6	247	130	1.6	58
ID315/2.1D	339.7	297	100	1.1	45

TABLE 12

Pipe type: R2
 Length: 6 m straight pipe
 Number of slots per rib: 3
 Slot width: 3.2 mm
 Type of perforation: LP

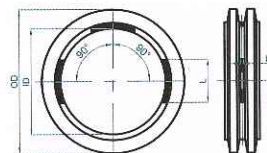

Pipe code ID or OD/3D 220°

220°					
PIPE CODE	OUTER DIAMETER	INNER DIAMETER	COLLECTION SURFACE		NO. OF SLOTS PER METER
			cm ² /m	% / m	
-	mm	mm	cm ² /m	% / m	-
ID200/3D	230.6	199	191	3.0	124
ID250/3D	282.6	247	237	3.0	116
ID300/3D	339.7	297	171	1.8	89

TABLE 13

Pipe type: R2
 Length: 6 m straight pipe
 Number of slots per rib: 4
 Slot width: 3.2 mm
 Type of perforation: TP

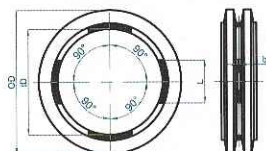

Pipe code ID or OD/4D 360°

360°					
PIPE CODE	OUTER DIAMETER	INNER DIAMETER	COLLECTION SURFACE		NO. OF SLOTS PER METER
-	mm	mm	cm ² /m	% / m	-
ID200/4D	230.6	199	191	3.0	166
ID250/4D	282.6	247	237	3.0	154
ID300/4D	339.7	297	285	3.0	119

TABLE 14

Pipe type: R2
 Length : 6 m straight pipe
 Number of slots per rib: 6
 Slot width: 4.8 mm
 Type of perforation: TP



Pipe code ID or OD/6D 360°

360°					
PIPE CODE	OUTER DIAMETER	INNER DIAMETER	COLLECTION SURFACE		NO. OF SLOTS PER METER
-	mm	mm	cm ² /m	% / m	-
ID400/6D	451.6	395.2	383	3.0	36
ID500/6D	563	493.4	471	3.0	36
ID600/6D	678	593	564	3.0	36
ID800/6D	906	795	762	3.0	36

2. KONTI KAN DRAIN HDPE SMOOTH PIPE

PRODUCT STANDARD:
EN 12201-2

DRAINAGE STANDARD:
BS 4962:1989;

DIN4262-1

MATERIAL: HDPE

DIMENSIONS: DN /OD

COLLECTION SURFACE CCA. 3%

TABLE 15

Pipe type: R3
Length: 6 m straight pipe
Slot width: 6 mm
Type of perforation: LP

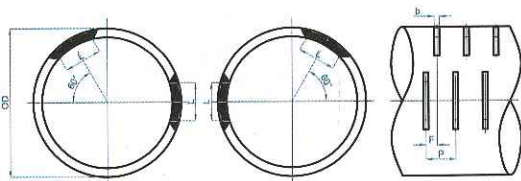

220°				
OUTER DIAMETER	SDR	INNER DIAMETER	COLLECTION SURFACE	
mm	-	mm	cm ² /m	% / m
110	9	85.4	81.0	3.0
	11	90	84.0	3.0
	13.6	93.8	87.0	3.0
	17	96.8	90.0	3.0
125	9	97	90.0	3.0
	11	102.2	96.0	3.0
	13.6	106.6	99.0	3.0
	17	110.2	105.0	3.0
140	9	108.6	102.0	3.0
	11	114.6	108.0	3.0
	13.6	119.4	111.0	3.0
	17	123.4	117.0	3.0
160	9	124.2	117.0	3.0
	11	130.8	123.0	3.0
	13.6	136.4	129.0	3.0
	17	141	132.0	3.0
180	9	139.8	132.0	3.0
	11	147.2	138.0	3.0
	13.6	153.4	144.0	3.0
	17	158.6	150.0	3.0
200	9	155.2	147.0	3.0
	11	163.6	153.0	3.0
	13.6	170.6	159.0	3.0
	17	176.2	165.0	3.0
225	9	174.6	165.0	3.0
	11	184	171.0	3.0
	13.6	191.8	180.0	3.0
	17	198.2	186.0	3.0
250	9	194.2	186.0	3.0
	11	204.6	192.0	3.0
	13.6	213.2	198.0	3.0
	17	220.4	207.0	3.0
280	9	217.4	207.0	3.0
	11	229.2	213.0	3.0
	13.6	238.8	222.0	3.0
	17	246.8	231.0	3.0
315	9	244.6	231.0	3.0
	11	257.8	240.0	3.0
	13.6	268.6	252.0	3.0
	17	277.6	261.0	3.0

TABLE 16

Pipe type: R3
 Length: 6 m straight pipe
 Slot width: 8 mm
 Type of perforation: LP

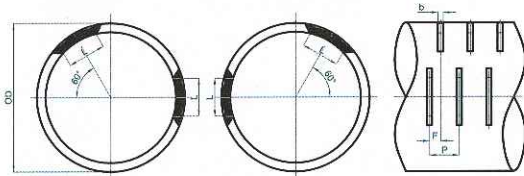

220°				
OUTER DIAMETER	SDR	INNER DIAMETER	COLLECTION SURFACE	
mm	-	mm	cm ² /m	% / m
110	9	85.4	80.0	3.0
	11	90	84.0	3.0
	13.6	93.8	88.0	3.0
125	17	96.8	92.0	3.0
	9	97	92.0	3.0
	11	102.2	96.0	3.0
140	13.6	106.6	100.0	3.0
	17	110.2	104.0	3.0
	9	108.6	104.0	3.0
160	11	114.6	108.0	3.0
	13.6	119.4	112.0	3.0
	17	123.4	116.0	3.0
180	9	124.2	116.0	3.0
	11	130.8	124.0	3.0
	13.6	136.4	128.0	3.0
200	17	141	132.0	3.0
	9	139.8	132.0	3.0
	11	147.2	140.0	3.0
225	13.6	153.4	144.0	3.0
	17	158.6	148.0	3.0
	9	155.2	148.0	3.0
250	11	163.6	156.0	3.0
	13.6	170.6	160.0	3.0
	17	176.2	164.0	3.0
280	9	174.6	164.0	3.0
	11	184	172.0	3.0
	13.6	191.8	180.0	3.0
315	17	198.2	184.0	3.0
	9	194.2	184.0	3.0
	11	204.6	192.0	3.0
315	13.6	213.2	200.0	3.0
	17	220.4	208.0	3.0
	9	217.4	208.0	3.0
315	11	229.2	216.0	3.0
	13.6	238.8	224.0	3.0
	17	246.8	232.0	3.0
315	9	244.6	232.0	3.0
	11	257.8	240.0	3.0
	13.6	268.6	252.0	3.0
315	17	277.6	260.0	3.0

TABLE 17

Pipe type: R3
 Length: 6 m straight pipe
 Slot width: 10 mm
 Type of perforation: LP

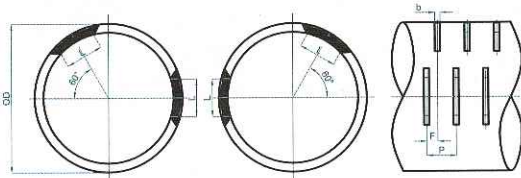

220°				
OUTER DIAMETER	SDR	INNER DIAMETER	COLLECTION SURFACE	
mm	-	mm	cm ² /m	% / m
110	9	85.4	80.0	3.0
	11	90	85.0	3.0
	13.6	93.8	87.0	3.0
	17	96.8	90.0	3.0
125	9	97	90.0	3.0
	11	102.2	95.0	3.0
	13.6	106.6	100.0	3.0
	17	110.2	105.0	3.0
140	9	108.6	102.5	3.0
	11	114.6	107.5	3.0
	13.6	119.4	112.5	3.0
	17	123.4	117.5	3.0
160	9	124.2	117.5	3.0
	11	130.8	122.5	3.0
	13.6	136.4	127.5	3.0
	17	141	132.5	3.0
180	9	139.8	132.5	3.0
	11	147.2	137.5	3.0
	13.6	153.4	142.5	3.0
	17	158.6	147.50	3.0
200	9	155.2	147.50	3.0
	11	163.6	152.5	3.0
	13.6	170.6	160.	3.0
	17	176.2	165.0	3.0
225	9	174.6	165.0	3.0
	11	184	175.0	3.0
	13.6	191.8	180.0	3.0
	17	198.2	185.0	3.0
250	9	194.2	190.0	3.0
	11	204.6	200.0	3.0
	13.6	213.2	205.0	3.0
	17	220.4	205.0	3.0
280	9	217.4	215.0	3.0
	11	229.2	225.0	3.0
	13.6	238.8	230.0	3.0
	17	246.8	230.0	3.0
315	9	244.6	230.0	3.0
	11	257.8	240.0	3.0
	13.6	268.6	250.0	3.0
	17	277.6	260.0	3.0

TABLE 18

Pipe type: R3
 Length : 6 m straight pipe
 Slot width: 4.8 mm
 Type of perforation: MP

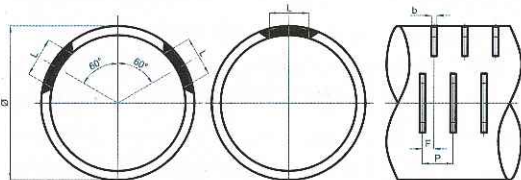

160°				
OUTER DIAMETER	SDR	INNER DIAMETER	COLLECTION SURFACE	
mm	-	mm	cm ² /m	% / m
355	9	276	259	3.0
	11	291	270	3.0
	13.6	303	288	3.0
	17	313	295	3.0
400	9	311	289	3.0
	11	327	304	3.0
	13.6	341	323	3.0
	17	353	334	3.0
450	11	368	346	3.0
	13.6	384	360	3.0
	17	397	360	2.9
500	13.6	426	384	2.9
	17	441	384	2.8
560	17	494	371	2.4

Besides these perforation solutions, the performance of the perforation equipment allows for a number of other perforation width and length solutions. For your solution, please contact the commercial sector of Konti Hidroplast.

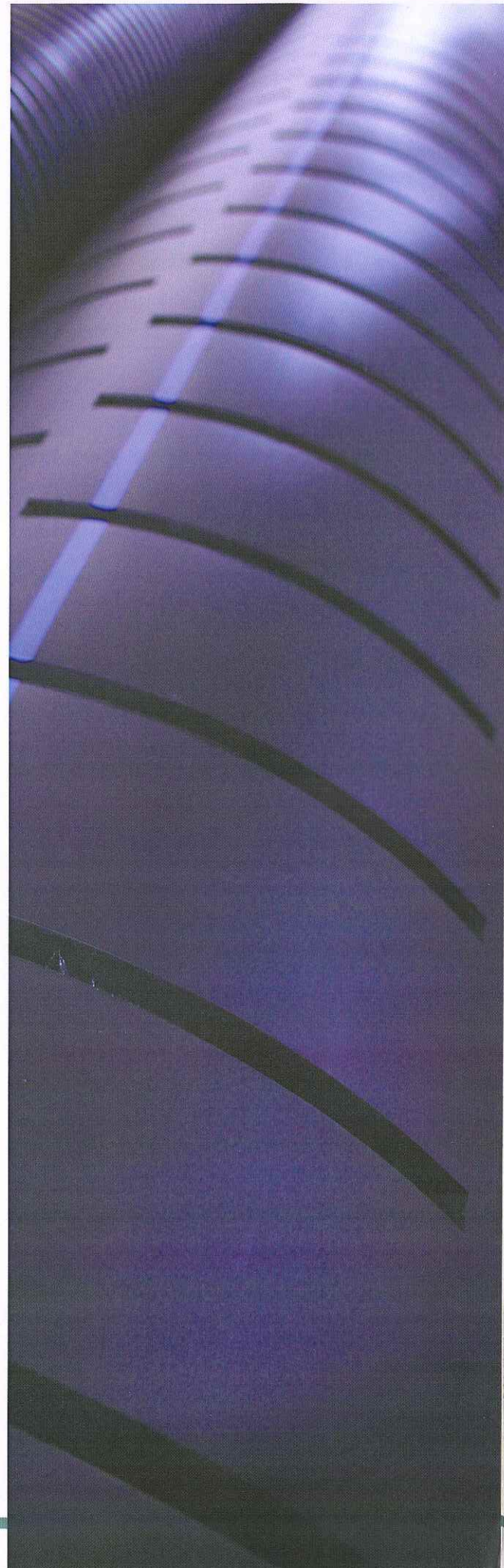



KONTI KAN DRAIN PP SUBSOIL DRAINAGE OF TRAFFIC AREAS

KONTI KAN PP HM Drain Pipe was developed specifically for use in tunnels and railroads. In these applications, the material is especially exposed to high static and the dynamic installation and flushing are provided with slot width of 5 mm. The pipes can be installed directly in the load area of railways and the solutions SN8 or SN16 are available depending on the static requirements.

KONTI KAN PP HM Drain are solid-wall drainage pipes compliant with DIN 4262-1, type R3, for use in sophisticated drainage systems.

APPLICATION

The main application is for drainage in tunnels and rail constructions with a special approval.

KONTI KAN PP HM Drain Pipe is particularly suitable for the following applications:

- Under high static and dynamic loads, even under rail loads
- With different soil conditions, e.g G3 (cohesive mixed soils, silt)
- For high surpluses
- With overfill of coarse backfill
- With frequent flushing of the pipeline



PRODUCT RANGE

- Partly-slotted, multi-purpose fully-slotted, pipes with 5 mm slotting and conveyance pipes
- Universal fittings range
- PP shaft range, DN 400 and 500
- DN 1000 shaft

PIPE DIMENSIONS

DN 160, 200, 250, 315



PROPERTIES

- Standard pipe length: 6 m
- Slot pattern:
 - LP partly-slotted (slotting approx. 220°)
 - MP multi-purpose (slotting approx. 120°, watertight sleeve connection with o-ring)
 - TP fully-slotted (slotting over the entire pipe cross section)
- UP conveyance pipe (unslotted, watertight with o-ring, for transporting drainage water)
- Standard slot width 5 mm, water admission area $\geq 100 \text{ cm}^2/\text{m}$
- Colour: black
- Ring stiffness according to EN ISO 9969 $> 8 \text{ kN/m}^2 = \text{SN8}$
- For use in the inner load area of railway loads, available in Sn16
- Compatible with all other standard designed pipes and fittings

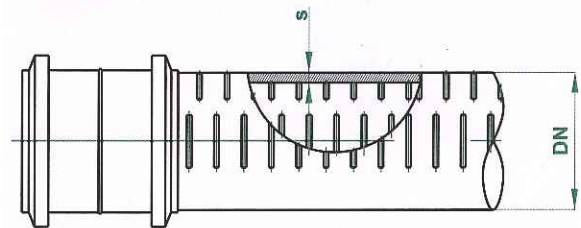

TECHNICAL INFORMATION

According to the issued European tunnel and rail approvals, the pipe can be used in different pressure zone of railway lines.

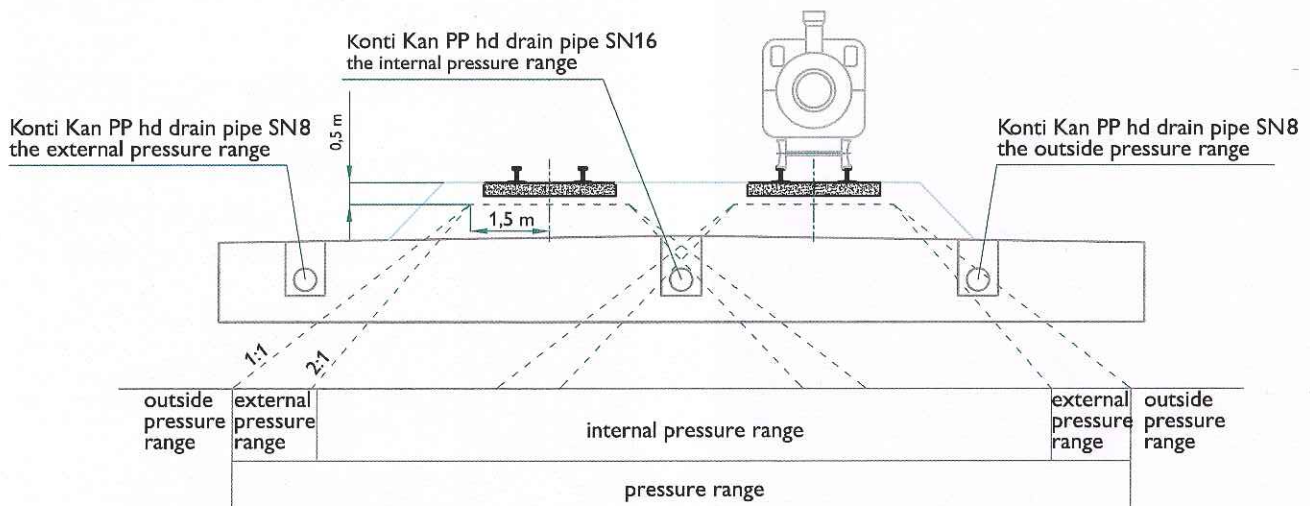



MATERIAL

KONTI KAN PP HM Drain pipe and fittings are made from high quality polypropylene with no added fillers.

Mechanical resistance: The material is characterized by high rigidity in the optimal combination with high impact strength. The unfilled material ensures excellent long-term resistance characteristics.

Chemical resistance: KONTI KAN PP HM Drain Pipe is resistant to acids and alkali (from pH 2 to pH 12).

KONTI KAN PP HM Drain Pipe possesses excellent thermal stability both at low and at high temperatures. There are no limits regarding the temperatures that generally occur in the media.

In addition, KONTI KAN PP HM Drain Pipe is characterized by high easiness of laying. Easy and fast installation is possible with the 6 m length and factory-plugged double sockets.

PRODUCT RANGE

KONTI KAN PP HM Drain Pipe SN 8 and SN 16 are high load-pipe system made of PP according to DIN 4262-1(type R3) with connected sockets, without recycled material, not foamed, not filled. Tested and quality controlled.

DN / OD	TYPE OF SLOTTING	COLLECTING SURFACE cm ² /m
160	TP	≥ 100
	LP	≥ 100
	MP	≥ 100
	UP	
200	TP	≥ 100
	LP	≥ 100
	MP	≥ 100
	UP	
250	TP	≥ 100
	LP	≥ 100
	MP	≥ 100
	UP	
315	TP	≥ 100
	LP	≥ 100
	MP	≥ 100
	UP	

(TP) FULLY SLOTTED

over the entire pipe cross section (360 °)

DN 160, 200, 250, 315,

The width of perforation of the tube is 5 mm

Water inlet area > 100 cm² / m

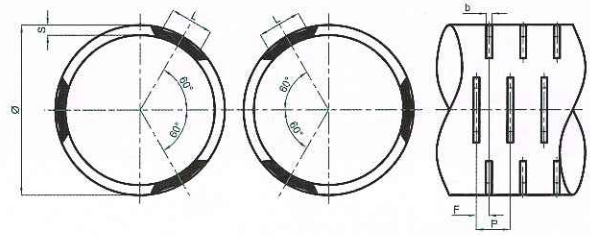

(LP) PARTIALLY SLOTTED DN 160, 200, 250, 315

Standard slot width 5 mm

Slotting at approximately 220° of the section

Water inlet area > 100 cm² / m

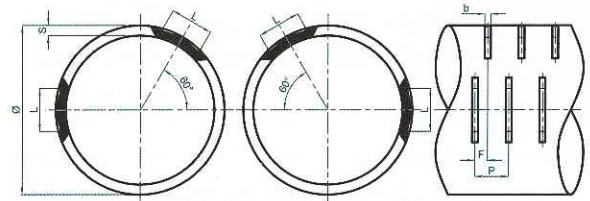

(MP) MULTI PURPOSE DN 160, 200, 250, 315,

Standard slot width of 5 mm

Slotting at over a maximum of 160° over cross section

Water inlet area > 100 cm² / m

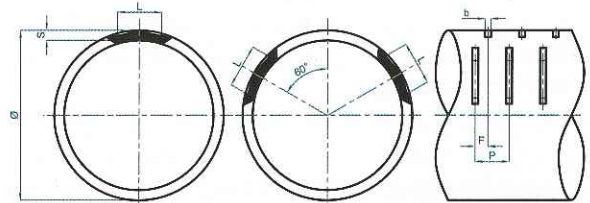

(UP) UNSLOTTED PIPE

Watertight with socket and rubber gasket, for transportation of drainage water, compatible with all range of standard fittings, according to EN 1852-1-, because of their standard dimension

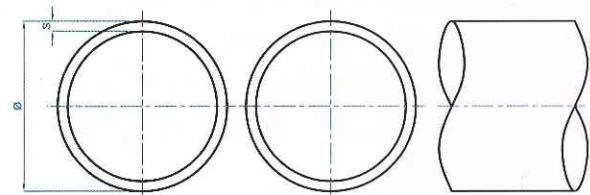

ADVANTAGES

The heavy duty pipe system made out of polypropylene without fillers PP-HM polypropylene compliant with DIN EN 1852 offers advantages at all levels – with safety for the highest demands:

- The solid-walled pipes ensure high impact resistance and very high resistance to point loads
- High quality under high static and dynamic loads
- Suitable for all soil types G1 to G3 as specified in EN 1610
- The smooth inner surface ensures excellent hydraulic characteristics, installation and the lowest gradient possible
- Pipes are high pressure, up to 340 bar flush cleaning and correspondent to the high demands needed at dewatering of the railway construction in the pipe system
- The standard slotting of the tube is 5 mm, according to DIN 4262-1
- Very high fall impact resistance
- These slots are easily cleaned by flushing
- These slots offer large protection against clogging of the water inlet
 - Extensive shaft and fitting range
 - High temperature resistance
- KONTI KAN PP HM Drain Pipes are compatible with the whole range of standard fittings, according to EN 1852-1, because of their standard dimensions

INSTRUCTIONS FOR TRANSPORTATION AND INSTALLATION

TRANSPORTATION

MATERIAL INPUT CONTROL

KONTI KAN PP HM Drain Pipe, fittings and sealing elements should be checked for any damage and completeness upon delivery. Furthermore, make sure that they match the requirements.

Damaged parts must not be installed and must be returned to the supplier.

UNLOADING OF THE VEHICLE

When unloading is done by an excavator or a crane, a belt must be used for unloading.

Ropes, chains or similar means are not permitted.

Tilting, throwing down or dropping of the pipes should be avoided.

Slings should be attached to the outer timber frame with a wooden frame and with a person to control by hand.

Unloading and handling this pipe at temperatures below 0°C should be specially treated or avoided.

STORAGE ON THE SITE

The storage of KONTI KAN PP HM Drain Pipe in timber frames should be on a flat, level surface.

The surface of these areas must be sufficiently strong to ensure that the pipes with packing will not sink.

The point loads should be avoided. For longer storage, outdoor pipes and fittings must be protected from direct sunlight. Storage periods of more than 1 year should be avoided. The height of the stored pipes should not exceed 1 m. The pipes should be protected against rolling off the side.

It should be done with minimum 2 wooden frames.

When stacking is done, it should be checked that the storage of crates is done wood on wood.

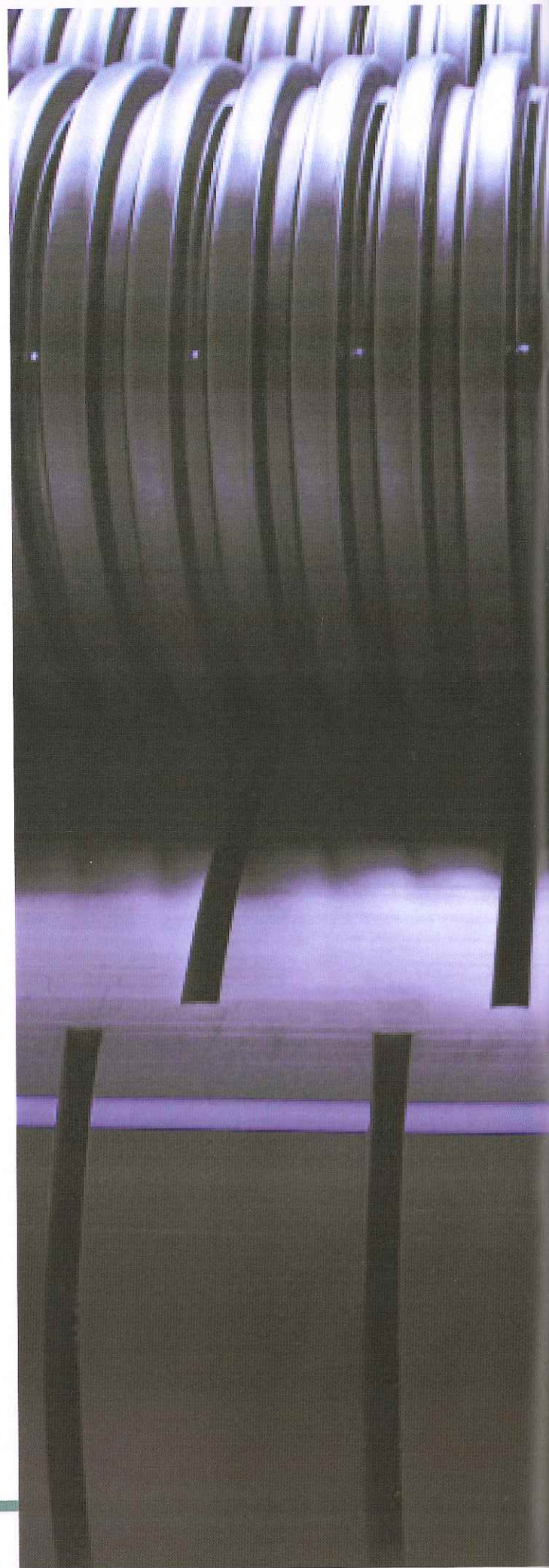

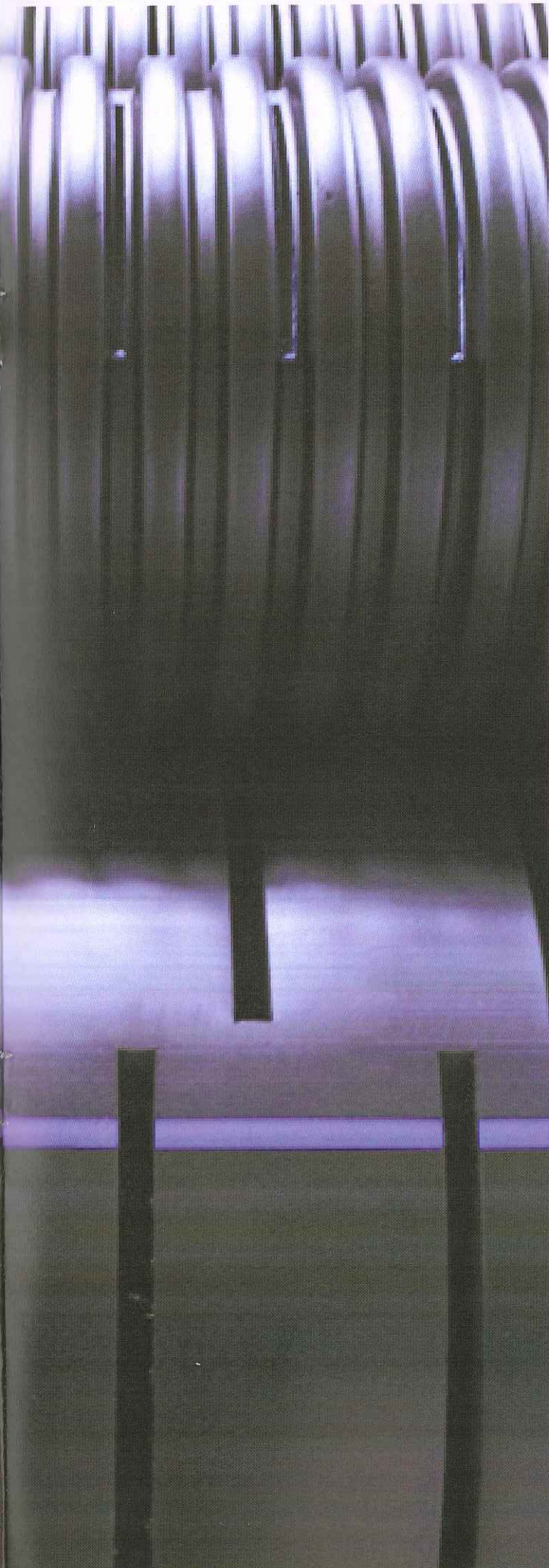

TRANSPORT TO THE PIPELINE TRENCH

For the transport of individual pipes and fittings of up to DN 250 for a pipeline trench, due to the low weight, no special lifting equipment is required.

In nominal sizes of 315 and 400 mm, the use of a lifting device is recommended. Lifting should be done only with a help of special lifting belts. Hooks, chains or other aids which can result in sharp or shock loads should be avoided.

EXCAVATION AND COMPACTION

For security reasons, the excavation width that least meet the requirements of DIN EN 1610.

The trench must be free of water until completion of the installation work. The layout of pipes in the trench should be done according to the rules for trench bedding, with good compaction of the soil, so as to avoid the point load problem.

PIPE SUPPORT EQUIPMENT

After excavation, the trench soil should be free of stones (over 32 mm particle diameter is not permitted).

The pipe bedding should be stone-free, with a minimum of 10 cm, compatible with the soil material according to the standard soil classification..

INSTALLATION

1. MATERIAL CONTROL

Before installation of pipes and fittings, they should be checked for damage. Damaged pipes or fittings should not be installed.

2. THE INSTALLATION OF KONTI KAN PP HM DRAIN PIPE must not be done at temperatures below 0 °C. At temperatures below + 8 °C special care must be taken when installing the pipes.

- Changes in direction by bending are not allowed. Use either welded fittings or shafts.
- The pipe joints and pipe spigot ends must be cleaned before installation.

- KONTI KAN PP HM Drain Pipe should be installed with the sockets against the direction of water flow. For multi-purpose tubes and non-slotted pipes, make sure that when connecting with the sockets, sealing gaskets are used.
- For all connectors of KONTI KAN PP HM Drain Pipe a lubricant has to be used. Oil or grease should not be used.

3. CUTTING OF KONTI KAN PP HM DRAIN PIPE can simply be done (right angle cut) by a fine-tooth saw or a pipe cutter and one should cut to the desired length. Burrs and irregularities of the partitions should be removed by a scraper or a knife. Spigot ends are chamfered.

PREPARATION OF THE DRAINAGE AREA

The drainage area (the area starting from the digging place to the beginning of the slits) starts with a pipe with the lowest available slot series in the compacted soil with a high percentage of fine particles ($k_f \leq 10\text{-}6\text{m/s}$), embedded (maximum particle diameter 32 mm). According the configuration and needs of the drainage zone, there is a zone of usage of partially slotted (LP) pipes and multi purpose pipes (MP).

The region of Partially slotted (LP) pipes has to be compacted by hand compaction. For multi-purpose pipes (MP), the area is filled with the same soil as the soil under the pipe and compacted by a hand compactor. After the compaction, it should be made sure that the pipe is not damaged by the hand compactor.

COMPACTION DEVICE

- A good compression process must be performed with great care. The contamination of the slots can be prevented by temporarily covering with foil and the layer is removed after the filling.
- In a zone of existing groundwater, it is recommended to use the Fully slotted (TP) pipes.
- They are filled with 15 cm thick layer.
- The compression of the cover directly over the pipe to 30 cm overlap should be done by hand.
- In order to avoid damage of the pipe, compacting soil on top of the pipe by a device must be avoided
- The compacting of the filling material should be made in layers. The shoring is gradually removed.
- The filling material should be of non-cohesive soils, the soil group G1 (according to ATV DVWKA127 = GE, GW, GI, SE, SW, SI). The crushed material used should have grain of maximum 16 mm diameter.
- The degree of compaction must be at least 95% Dpr.

BACKFILLING OF THE TRENCH

The backfilling of the trench must be done in accordance with DIN EN 1610. The overfill has to be done in layers. For a cover of 0.3 m to 1.0 m only light compaction equipment can be used. Hence, only standard compression devices are used.

INSPECTION AND CLEANING OF THE INSTALLED PIPE

The installation process is completed after checking the integrity of the connection by a swiveling camera and a colour image and examining of flow. Prior to the camera inspection, the pipeline should be cleaned with high pressure flushing.

KONTI KAN PP HM Drain Pipes are cleaned with a flushing pressure of 320 bar.

TYPICAL TRENCH

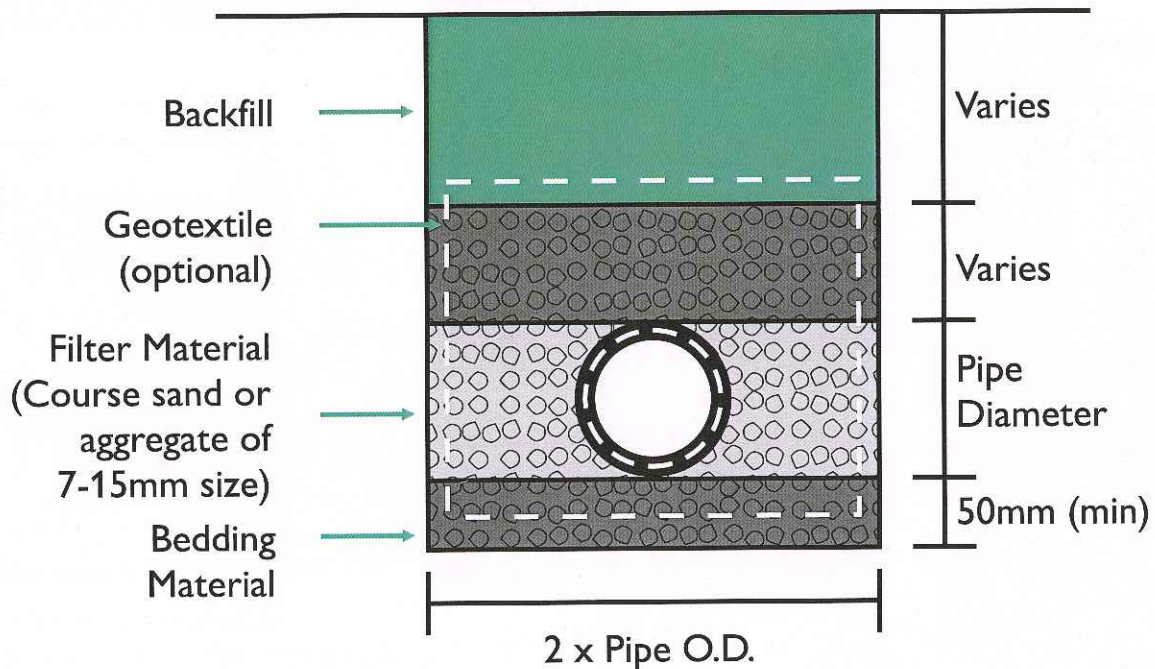

STANDARDS

DIN 4262-1

Pipes and fittings for subsoil drainage in traffic areas and underground engineering part 1: pipes, fittings and their joints made from PVC, PP and PE

EN ISO 9969

Thermoplastics pipes. Determination of ring stiffness

EN 1852-1:2009

Plastic piping systems for non-pressure underground drainage and sewerage. Polypropylene (PP). Specifications for pipes, fittings and the system

1610

Construction and testing of drains and sewers

EN 13476-3:2007+A1:2009

Plastic piping systems for non-pressure underground drainage and sewerage. Structured-wall piping systems of non-plasticized polyvinyl chloride (PVC-U), polypropylene (PP) and polyethylene (PE). Specifications for pipes and fittings with smooth internal and profiled external surface and the system, Type B

EN12201-2:2003

Plastic piping systems for water supply – Polyethylene (PE) – Part 2: Pipes



**KONTI
HIDROPLAST®**



NORTH MACEDONIA
1480 Gevgelija, Industriska bb



+389 34 212 064 +389 34 215 225
+389 34 211 757 +389 34 215 226



+389 34 211 964



contact@konti-hidroplast.com.mk
hidroplast@t-home.mk



www.konti-hidroplast.com.mk



qualityaustria
Succeed with Quality

EXACT

IG+

MAY, 2019